

Millboard Envello Shadow Line+ Vertical Cladding System



CONTENTS

1.0	APPLICATION & SAFETY STATEMENT		6.0	INSTALLATION	
2.0	ABOUT ENVELLO CLADDING		7.1	Corners	31
2.1	About	05	7.2	Inter Story Junction	36
2.2	Product Overview	06	7.3	Joining Boards	37
3.0	PRODUCT SUITABILITY		7.4	Windows and Doors	38
3.1	Intended Use & Limitations	08	7.5	Wall Penetrations	40
4.0	PRE-INSTALLATIONS		7.6	Installation Abutting Rendered Surface	43
4.1	Storage & Handling	10	7.7	Barge Detail	44
4.2	Board Set-Out	11	7.8	Parapets	45
4.3	Tools & PPE Required	11	7.9	Transition to Brick/Monolithic	46
4.4	Cutting	12			
4.5	Fire Performance	12			
5.0	MATERIALS				
5.1	Colour Characteristics	14			
5.2	Material Calculator	16			
5.3	Accessories	18			
5.4	Fixings	20			
5.5	Cut End Colour Matching	21			
5.6	Additional Items	22			
6.0	PREPARATION				
6.1	Cavity Batten Layout	25			
6.2	Fixings	26			
6.3	Base to Wall (Concrete Floor)	27			
6.4	Windows and Soffits	29			

1 . 0

APPLICATION & SAFETY STATEMENT

Read these instructions in full before starting installation

The information in this Installation Guide is intended for competent, licensed building practitioners. It must be read together with the **Millboard Envello Vertical Cladding Design Guide, project drawings and the current New Zealand Building Code (NZBC)**.

Installer Obligations

- Envello Cladding must be installed by a competent Licensed Building Practitioner
- Install Envello Cladding strictly in accordance with the latest Envello Cladding instructions, relevant standards and local building regulations.
- Use only approved fasteners, accessories and safety procedures.
- Verify that the product meets visual/aesthetic requirements **before fixing**. Forté will not be responsible for aesthetic concerns and variations that are apparent after installation.

Warning

Failure to follow these instructions may result in personal injury, property damage, non compliance with the CodeMark certificate, and **will void the Millboard Envello Cladding warranty**.

Exclusion of Liability

Other than the rights and remedies that cannot be excluded under New Zealand law, Forté provides the Envello product **“as is”** and excludes all other warranties, conditions and liabilities (whether in contract, tort—including negligence—or otherwise). Forté is not liable for any indirect or consequential loss arising from installation or use of Envello Cladding. Where doubt exists, seek advice from a Chartered Professional Engineer or Forté Technical Support **before proceeding**.

ABOUT ENVELLO CLADDING



2.1	About	05
2.2	Product Overview	06

2 . 1

ABOUT

Envello cladding uses a unique material, unrivalled across the globe. Take a closer look at the construction and performance of this stunning yet functional cladding.

TOUGH	The unique surface layer is more resistant to scratches and is designed to better withstand demanding outdoor environments
ENDURING	The dual-tone surface layer is hand coloured using pigments designed to improve resistance to sun damage and fading.
BEAUTIFUL	Each length is hand moulded using specially selected timber masters for an unrivalled organic wood-grain appearance in a resin mineral board material.
FIRE RATED	Shadow Line+ is fire rated to NZ Fire Rating Group 3 (D-s3, d0) for added assurance and quality.
DURABLE	Envello will not split, rot or harbour insects like timber does.
LIGHTWEIGHT	Our unique closed 'cellular' internal structure reduces weight while maintaining strength and increasing thermal performance.
STRONGER	The structural core is a blend of natural minerals bonded in a polymer resin with renewable biopolymers and fibre reinforcement for added strength and durability.
WOOD FREE	Envello cladding is wood-free and non-porous which, in comparison to timber, means there's no leaching or releasing of tannins to other surfaces.

2.2

PRODUCT OVERVIEW

A smooth and authentic timber-look cladding board with an enhanced offering.

The Shadow Line+ board has been designed to perfectly replicate smooth timber with a flat grained finish, giving a clean authentic look. The increased width of Shadow Line+ boards, compared to standard timber boards, ensures larger grain detail and enhanced visual impact, without the risk of the board twisting or warping over time. The indent created between boards gives definition to the individual grain patterns, adding to the overall authentic timber-look aesthetic.

Another key feature of Shadow Line+ is its weather resistance. As with Millboard's decking composition, Shadow Line+ is formulated with the same unique mineral mix, further developed to achieve the required fire rating.

01

Environmentally friendly



02

Does not warp or rot like wood



03

UV & weathering stability



04

Increased thermal performance



05

Resistant to algae



06

Moulded from real oak



07

Lightweight



08

Wood-free



Crafted to be perfectly imperfect

The moulds used to create Envello cladding boards have been specially crafted from carefully selected oak timber. The fine detail and natural imperfections of the oak ensure each board has an authentic timber-look. From the initial laying of the elastomeric surface, right through to the pouring of the fibre-reinforced resin mineral, and hand-colouring each board individually, Envello guarantees a quality, unique finish with added durability due to enhanced technology and craftsmanship.

PRODUCT SUITABILITY



3.1

INTENDED USE & LIMITATIONS

The following guidance outlines where the Forté Envello Cladding System can be used, and any limitations or conditions that apply to ensure safe, compliant and long-lasting installations.

Intended Use

Envello cladding has been designed as a cladding system for low-rise residential and select commercial buildings that are;

- Up to 10m in height and greater than 1m from the boundary
- In wind zones up to and including extra high as defined in NZS 3604:2011
- To design wind pressure (ULS) of 2.1kpa

To ensure the best installation and long-term performance, Envello cladding is to be installed by a professional or experienced trades person LBP.

It is the property owner's responsibility to make sure that the plans meet relevant NZBC building codes before the installation of the Envello cladding System commences. Envello cladding must also be supported by a suitable substructure that is in accordance with the NZBC (New Zealand Building Code) NZS 3604:2011

Envello cladding is a wall cladding system installed over a drained cavity, comprising an outer skin of cladding boards fixed through cavity battens into the wall framing, with wall underlay behind. In accordance with NZBC E2/AS1.

The system is certified under CodeMark Certificate CMNZ70204 for use as exterior wall cladding on a drained cavity for timber-framed buildings within the scope of E2/AS1.

Envello Cladding is not a structural bracing element and does not contribute to the bracing capacity of the wall. All structural bracing requirements must be satisfied independently by the building's structural frame in accordance with NZS3604:2011.

Performance

When installed and maintained by a qualified trades person, using accepted trade practices as specified in this manual, it will meet the applicable requirements of the NZBC;

- B1 Structure (3rd Edition)
- B2 Durability (3rd Edition)
- E2 External Moisture (4th Edition)
- F2 hazardous Building Materials (1st Edition)

Warranty

The Envello cladding System has a 15 year limited structural warranty. Refer to [our website](#) for more details.

Limitations

This installation guide is not exhaustive as the responsibility for design lies with the specifier or responsible party for the project to ensure the final design meets the requirements of the intended application and relevant building codes.

It is the responsibility of designers, installers, and owners to ensure that the information in this manual is current, by checking with Forté or referring to our website. As new technology is introduced or industry standards are altered, Millboard reserves the right to alter existing specifications and remove products without notice. Visit the Forté website at www.forte.co.nz for more information.

The use of this manual does not guarantee acceptance or accreditation of a design, material or building solution by any entity authorised to do so under law; does not mean that a design, material or building solution complies with the building codes; or does not absolve the user from complying with any local, or Government legal requirements.

PRE-INSTALLATION



4.1	Storage & Handling	10
4.2	Board Set-Out	11
4.3	Tools & PPE Required	11
4.4	Cutting	12
4.5	Fire Performance	12

4 . 1

STORAGE & HANDLING

Envello cladding boards should always be stored on a flat surface at a maximum of 400mm apart. The boards must be stacked with both prefinished sides facing each other, not back-to-face and both external and internal corner profiles should be fully supported along their length.

When loading and unloading by hand, ensure both ends of the board are lifted on the edge to avoid permanent deformation and/or damage.

The boards should only be lifted off the stack, not dragged, to eliminate the risk of marking the surface. The boards should be carried on their side, by two people, for increased rigidity. It is recommended that gloves and long sleeves be worn when handling the boards and extra care is taken when lifting and carrying them.

It is recommended that the cladding boards are stored on site at least 72 hours before installation to allow the boards to acclimatise.

Forté do not take responsibility for damage caused by improper storage and handling of the product.

Tolerances

There will always be a slight variance in the board's dimensions due to the boards being moulded from natural oak, and the pressure of the moulding process. Despite this, each board is calibrated to ensure a consistent profile is maintained.

The manufacturing tolerances are: Width: $\pm 3\text{mm}$. Length: $\pm 5\text{mm}$. Thickness: $\pm 2\text{mm}$.

When working with the boards, a level may be required to help keep the boards running upright. In order to achieve straight and consistent 5-6mm gapping between boards, it may be necessary to use Envello Multi-Spacers during the installation process.

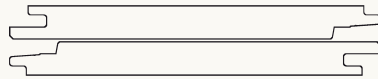

Stack boards face-to-face

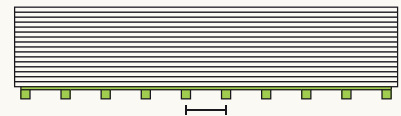

Ensure boards are on a flat surface or bearers max. 400mm apart



Lift boards on the edges using 2 people to lift at a time

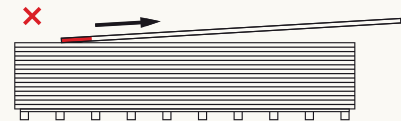

Do not drag the boards off the stack

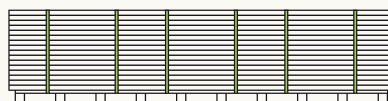

Ensure boards are secured to the pallet before transporting

4 . 2

BOARD SET-OUT

Envello has up to five different grain patterns to ensure a random grain pattern layout.

The boards should be sorted into piles of the different grain patterns prior to installation. When installing the cladding boards, ensure that you pull from a different pile each time and alternate the board end cuts to further vary the grain pattern layout.

4 . 3

TOOLS & PPE REQUIRED

Please refer to the below tools and PPE required to install Envello cladding.

If you are unsure on how to use any tools, please consult the manufacturer's user manual.

- Mitre saw/jigsaw/handsaw: Envello cladding products can be cut with standard wood cutting tools. We recommend using a carbon-tipped saw blade to cut the boards and an aluminium cutting blade for the metal trims.
- Tool set: Standard carpentry tools will be needed to complete the installation, including a tape measure, pencil, set square, planer, stanley knife, surform and a drill bit set.
- Spirit level: A spirit level is used to ensure that the battens are level and the boards are upright.
- Personal Protective Equipment: When handling Envello products, it is advised to wear long sleeves and gloves. When cutting products, we recommend wearing a FFP3 dust mask, ear muffs and safety glasses.
- Power drill and driver: Standard power drill drivers can be used to fix the cladding boards.

4 . 4

CUTTING

Accurate cutting is essential to achieving a clean, professional finish, ensuring proper board alignment, maintaining product integrity and preserving the overall appearance of the cladding system.

When cutting Envello boards or corner profiles with standard wood cutting tools, we recommend using a carbon-tipped saw blade (a dust bag or vacuum must be used on mitre saws).

For the metal trims, an aluminium cutting blade should be used. Ensure the boards are adequately supported when cutting with the boards facing up for a cleaner finish.

When the board is cut, touch-up coating should be used if the cut is visible and exposed to UV. Dispose of the off-cuts as general waste, don't burn them at home.

IMPORTANT :

- Work in outdoor areas with ample ventilation.
- Minimise dust from cutting by using a mitre saw with a dust bag or vacuum.
- Warn other in the immediate area to avoid breathing dust.
- Wear the correct PPE (long sleeves and gloves, FFP3 dust mask, ear muffs and safety glasses).
- If there is a breeze/wind when cutting the boards, locate the saw downwind so the excess dust is blown away from the operator and other in the immediate area.

4 . 5

FIRE PERFORMANCE

Envello Shadow Line+ cladding boards are crafted with fire retardants in the board composition and have been tested to NZ Fire Rating Group 3 ensuring they have a classification of D-s3, d0.

In general, Shadow Line+ cladding can be used on low rise residential and some commercial properties that are below 10m in height and are more than 1m from the boundary. The responsibility for the cladding's suitability in the required location is to be determined by a certified building professional (building control, building insurance, fire officer).

Forté does not take responsibility for incorrect specification, application, or product installation in areas not in accordance with NZ government guidance. Current guidance should be gained from the government website relating to the geographic location of the project.

MATERIALS



5.1	Colour Characteristics	14
5.2	Material Calculator	16
5.3	Accessories	18
5.4	Fixings	20
5.5	Cut End Colour Matching	21
5.6	Additional Items	22

5.1

COLOUR CHARACTERISTICS

Envello cladding is crafted to replicate timber's natural tonal variations, offering durable, low-maintenance performance. Colour differences between boards are intentional and enhance its authentic appearance and long-term weathering character.

Great care and consideration go into ensuring each Envello cladding board has a unique timber-look appearance. To achieve the look of natural timber, secondary toning colours are used, which may result in colour variance within the same board or between boards.

Envello cladding has been designed to replicate the natural variances of timber and is manufactured to have tonal variance in the colour.

To reduce the amount of variation between boards, Envello cladding product should be purchased in one order to ensure the colour is consistent. If you have multiple batches for your project, purchased at different times, it is recommended to mix the boards from different batches to help with balancing out the colour variation.

It is important to note that the Antique Oak cladding product has more tonal variation per individual board than any of the other colours in the Envello range. As with all products exposed to the sunlight (UV), Envello will naturally weather and tone down over time. Loss of gloss is perfectly normal and will not affect the performance of the products.

Upon delivery, if you find the colour unacceptable or believe them to be defective in any way, please contact a Forté representative. If there are any unforeseen issues with the boards, this should be highlighted with Forté before installation.

Envello cladding is made to last. The careful steps taken to hand-mould and colour each board, further enhanced by its high performance, durability and low-maintenance, ensures it outperforms other timber alternative products on the market.

Antique Oak boasts more tonal variation per individual board than the other colours in the Envello range.





LIMED OAK



SMOKED OAK



ASHWOOD



GOLDEN OAK



COPPERED OAK



ANTIQUED OAK



EBONY GREY



BURNT CEDAR

5.2

MATERIAL CALCULATOR

The area (m2) is the total wall area to be clad.

- Area (m2) = [(width x height) – (area of any windows & doors)]
- Number of boards = m2 x 1.54

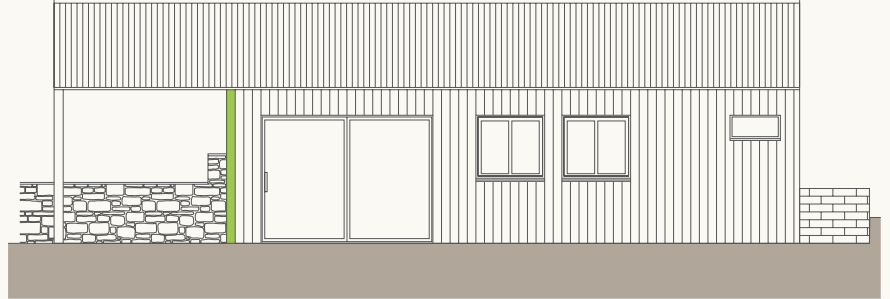

Vertical Installation

Perforated closures will be needed at the bottom of the cladding and above any window or door heads

Number of perforated closures =

$$\frac{[(\text{width of cladding area}) + (\text{width of all windows}) + (\text{width of all doors})]}{3}$$



Corners

External/Internal Corner Profiles =

$$\frac{\text{total linear m for corners}}{3}$$

Extra perforated closures = Number of corner profiles

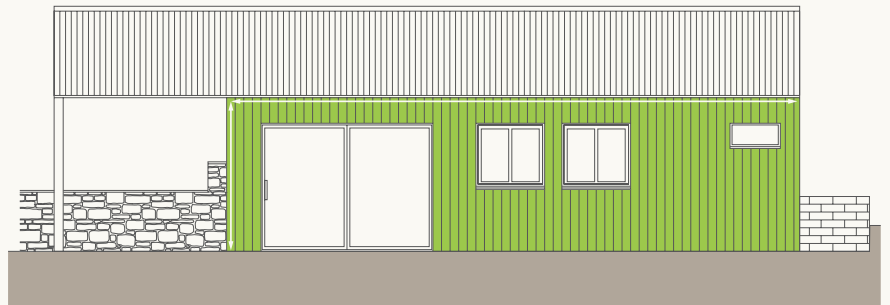

Fixings

Number of boxes

75mm fixings =

$$\frac{\text{number of cladding boards} \times 10}{250 \text{ (number of screws per box)}}$$

20mm fixings =

$$\frac{\text{number of perforated closures} + \text{corner profiles} \times 14}{250 \text{ (number of screws per box)}}$$

Envello Coloured Head Screws =

$$\frac{\text{number of cladding boards}}{100 \text{ (number of screws per box)}}$$

TIP

Allow extra material for wastage and offcuts. We would recommend adding at least 10% to the quantities, as complex designs may require more material

5.3

ACCESSORIES

**Envello Shadow Line+
Cladding Boards**



**Prefinished Reveal Boards
For Window Detailing**



**Shadow Line+ External
Y Flashing**



DIMENSIONS	200 x 18 x 3600mm	16mm T x 146mm W x 3600mm L	50mm T x 50mm W x 3600mm L
APPLICATION	For vertical use only on low-rise residential and some commercial projects	For finishing the edges around windows/doors	Designed to create a seamless mitred corner. Can be colour matched to colorsteel range
EFFECTIVE COVER	180mm	-	-
BOARDS PER M²	1.54	-	-
FIXINGS	75mm fixings Coloured Head screws	Coloured Head screws	20mm fixings
PRODUCT CODES	Smoked Oak ESL-S Antique Oak ESL-A Golden Oak ESL-G Burnt Cedar ESL-BC Limed Oak ESL-L Coppered Oak ESL-C	Smoked Oak ERB-S Antique Oak ERB-A Golden Oak ERB-G Burnt Cedar ERB-BC Limed Oak ERB-L Coppered Oak ERB-C	Smoked Oak EYF-S Antique Oak EYF-A Golden Oak EYF-G Burnt Cedar EYF-BC Limed Oak EYF-L Coppered Oak EYF-C

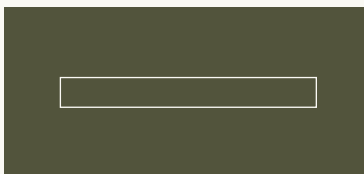
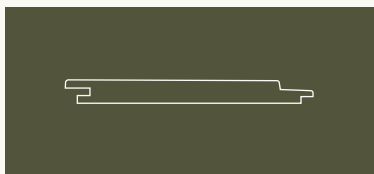

**Shadow Line+ External
Corner Profile**



**Shadow Line+ Internal
Corner Profile**

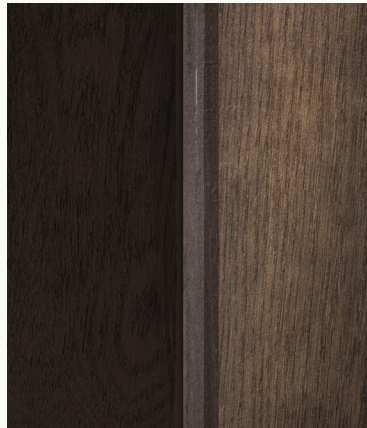

**Perforated
Closure Trim**



DIMENSIONS

50mm T x 50mm W x 3050mm L

38mm T x 38mm W x 3050mm L

50mm T x 25mm W x 3000mm L

APPLICATION

Finishing off the external corner of a building. Only recommended to go as high as one board length

Finishing off the internal corner of a building. Only recommended to go as high as one board length

To prevent pests getting into the cavity behind the boards, whilst allowing airflow

FIXINGS

Perforated closure, 20mm fixings.

Perforated closure, 20mm fixings.

20mm fixings

PRODUCT CODES

Smoked Oak EEC-S
 Antique Oak EEC-A
 Golden Oak EEC-G
 Burnt Cedar EEC-BC
 Limed Oak EEC-L
 Coppered Oak EEC-C

Smoked Oak EIC-S
 Antique Oak EIC-A
 Golden Oak EIC-G
 Burnt Cedar EIC-BC
 Limed Oak EIC-L
 Coppered Oak EIC-C

EA-PCT

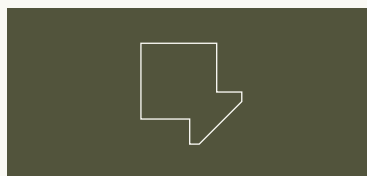
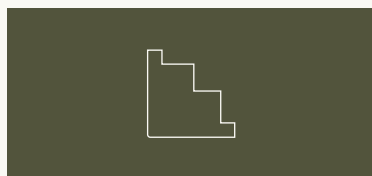

5.4

STAINLESS STEEL FIXINGS



FIXING SCREWS - CLADDING BOARDS

Envello Cladding boards should be fixed through the tongue using cladding fixings – one fixing at each batten intersection, and two fixings per batten where boards are joined. Fixings should be inserted through the guide groove on the tongue, angled slightly toward the board, with the head sitting flush with the surface.

	20MM CAVITY ON FLEXIBLE	20MM CAVITY ON RAB	45MM STRUCTURAL CAVITY
DIMENSIONS	4.2mm W x 65mm L	4.2mm W x 75mm L	4.2mm W x 45mm L
FORMAT	Box of 250	Box of 250	Box of 250

20MM ACCESSORY SCREWS - PERFORATED CLOSURE SCREWS

Perforated closures should be used using the 3.5x20mm fixing screw.

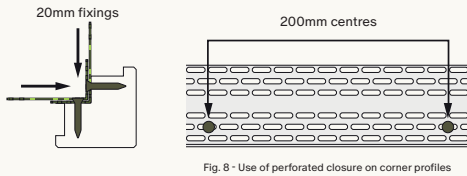

DIMENSIONS	3.5mm W x 20mm L
FORMAT	Box of 250



COLOUR HEAD FIXING SCREWS

Colour head screws are surface fixed through the cladding board, so the head sits flush with the top layer of the board.

DIMENSIONS	3.5mm W x 40mm L
FORMAT	Box of 100



5.5

CUT END COLOURING MATCHING

Envello cladding is crafted to replicate timber's natural tonal variations, offering durable, low-maintenance performance. Colour differences between boards are intentional and enhance its authentic appearance and long-term weathering character.

When Envello boards are cut to length, the exposed ends may reveal a lighter core material. Although this has no effect on the board's durability or performance, applying touch-up coating can improve the visual continuity of the installation—particularly in high-visibility areas or where the ends are exposed.

Envello is inert in composition and does not require end-grain sealing for protection. The use of touch-up coating is purely aesthetic and optional, but recommended where a uniform appearance is desired. The coating is available in colours matched to the standard Envello ranges for ease of application on site.

Please note, this product is not suitable for repairing boards or touching up the surface/face of the boards. The colour is not a perfect match and is not durable due to it being a water-based material.

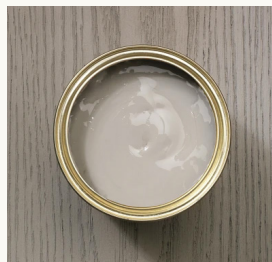

SMOKED OAK



LIMED OAK

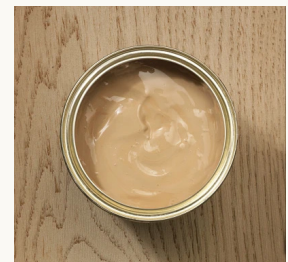

ASHWOOD



GOLDEN OAK

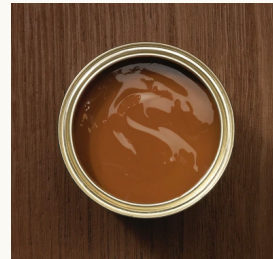

COPPERED OAK



ANTIQUE OAK



EBONY GREY



BURNT CEDAR

5.6

ADDITIONAL ITEMS

(Supplied by Others)

The correct additional items are essential for structural stability, weatherproofing and precise detailing, ensuring the cladding performs as intended.

- Flashings around windows, doors, interstory junction etc
- Fixings for installing the battens on to the structure (suitable type of fixing for the structure and battens used)
- Screws for fixing the battens together (suitable type of screw for the location and battens used)
- Sikaflex 11FC adhesive
- Suitable H3.2 treated timber cavity battens



PREPARATION



6.1	Cavity Batten Layout	25
6.2	Fixings	26
6.3	Base to Wall (Concrete Floor)	27
6.4	Windows and Soffits	29

6.1

CAVITY BATTEN LAYOUT

The time and care taken on setting and fixing the support system correctly will be reflected in the finished result. Time spent ensuring corners are upright and battens are straight will allow easier and faster installation and achieve a superior finished result.

Suitable H3.2 treated timber battens can be used as the cavity battens for the cladding boards. All cavity battens and details should comply with B2/AS1 as per E2/AS1 9.1.7.8. The cavity battens should be a minimum size of 18mm thick & 45mm wide, castellated cavity battens are shown throughout this guide.

The battens need to be fixed into either the main framework of the building structure or to the noggins at centres suitable for the battens.

The battens at the top and bottom of the window/doors should be so that the board ends are supported; all horizontal battens should be level.

The Perforated closure is suitable for batten sizes of 20 or 45mm, if battens used are different to these sizes, then perforated closures or flymesh sourced by other suppliers should be used. It is best for the perforated closure to be held between the back of the battens and the wall. This should be taken into consideration when fixing the battens, alternatively they can be fixed to the front of the battens using the 20mm accessory fixings.

Determine at what height the cladding is to start at. The bottom of the cladding boards should have sufficient clearances from other surfaces and should be in accordance with E2/AS1.

- A minimum clearance of 175mm above unpaved ground and 100mm above paved ground.
- Cladding must overlap the bottom plate by 50mm.
- Cladding above deck must have a 35mm gap.
- Decking running into cladding must have a 12mm standoff.
- Use a laser line or level, mark up a level line around the building or along the wall that is to be clad. This line will be the bottom of the first board.

Battens should be fixed to the structural wall using suitable external grade fixings.

- For fixing to a timber frame, the battens should preferably be fixed into the timber studs of the frame or into the noggins/dwangs.
- The battens should be fixed level and packers may be needed for these if the wall is undulating.
- Batten spacing at the bottom of the wall must have 2 cavity battens spaced 200mm apart, to ensure the cladding is properly supported.

PRODUCT	Shadow Line+
CAVITY BATTEN SPACING	400mm
CAVITY BATTEN SPACING FOR HIGH LOAD AREAS	400mm

BATTEN LAYOUT

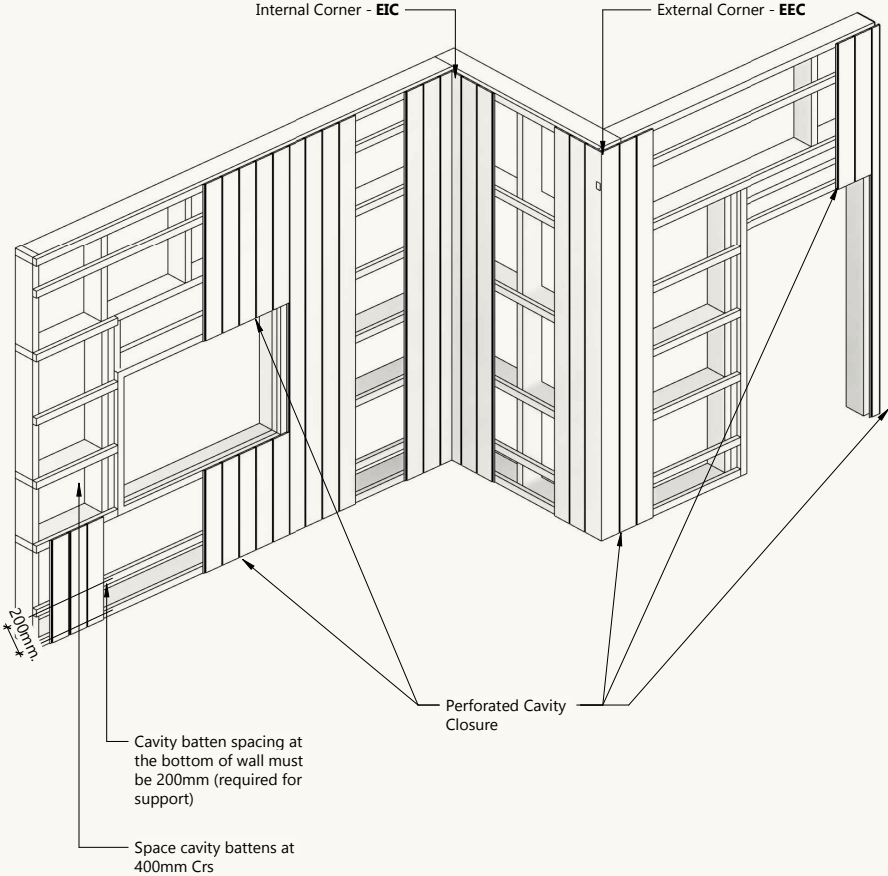

6 . 2

FIXINGS

Correct fixing of Envello cladding ensures secure installation and alignment. Boards are fixed through the tongue, with face-fixing required around openings and edges for a neat, stable finish.

Envello cladding boards must be fixed through the tongue with a cladding fixture to achieve minimum 30mm embedment into the structure. There should be one fixing per batten intersection and two per batten when joining boards. The fixings should be inserted through the fixing guide groove on the tongue and angled towards the board slightly with the head sitting flush with the surface. The fixings do not need to be predrilled or countersunk as the boards will naturally allow the head to slightly countersink. Once the first board has been installed, the second board can be installed beside it, with the groove covering the tongue of the previous board. Refer Table C.3.1.1 E2/AS1.

It is recommended to check the boards against a level every fourth or fifth board to ensure that the boards are aligned vertically. Adjustments to the spacing between the boards may be required.

When the tongue is taken off the boards to fit around windows and doors, or at the edge of a building, 40mm coloured head screws will need to be used through the board face.

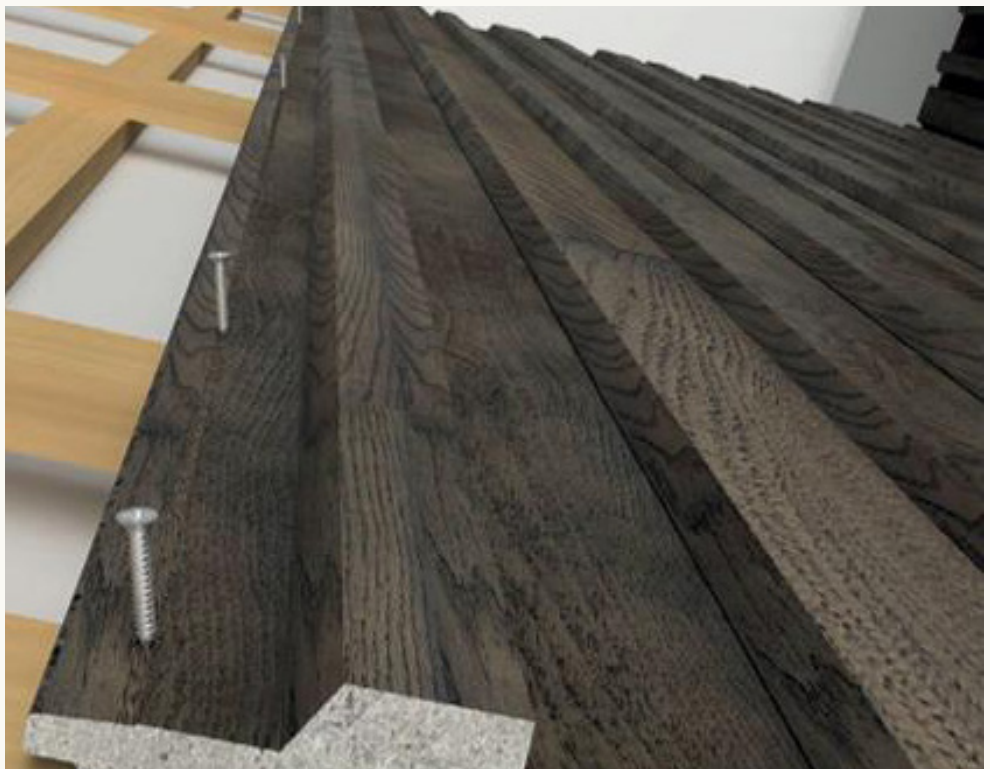

6.3

BASE TO WALL (CONCRETE FLOOR)

Drainage cavity for the control of moisture is a key element in the design and construction of cladding. It is a requirement (as per NZBC E2 3.5) not an option and should not be overlooked.

An 18mm minimum open cavity should always be provided behind the cladding and to dissipate any condensation or drainage at the bottom.

Cavity closures should always be used to create drained and vented cavities. Where possible, ventilation pathways for cavities should be provided at the bottom of the cavity and above the window head.

Insect and rodent invasion should also be considered, and a perforated closure should be used to counter these threats where there is the required air gap, whilst still maintaining the required air flow.

BASE TO WALL – GROUND LEVEL

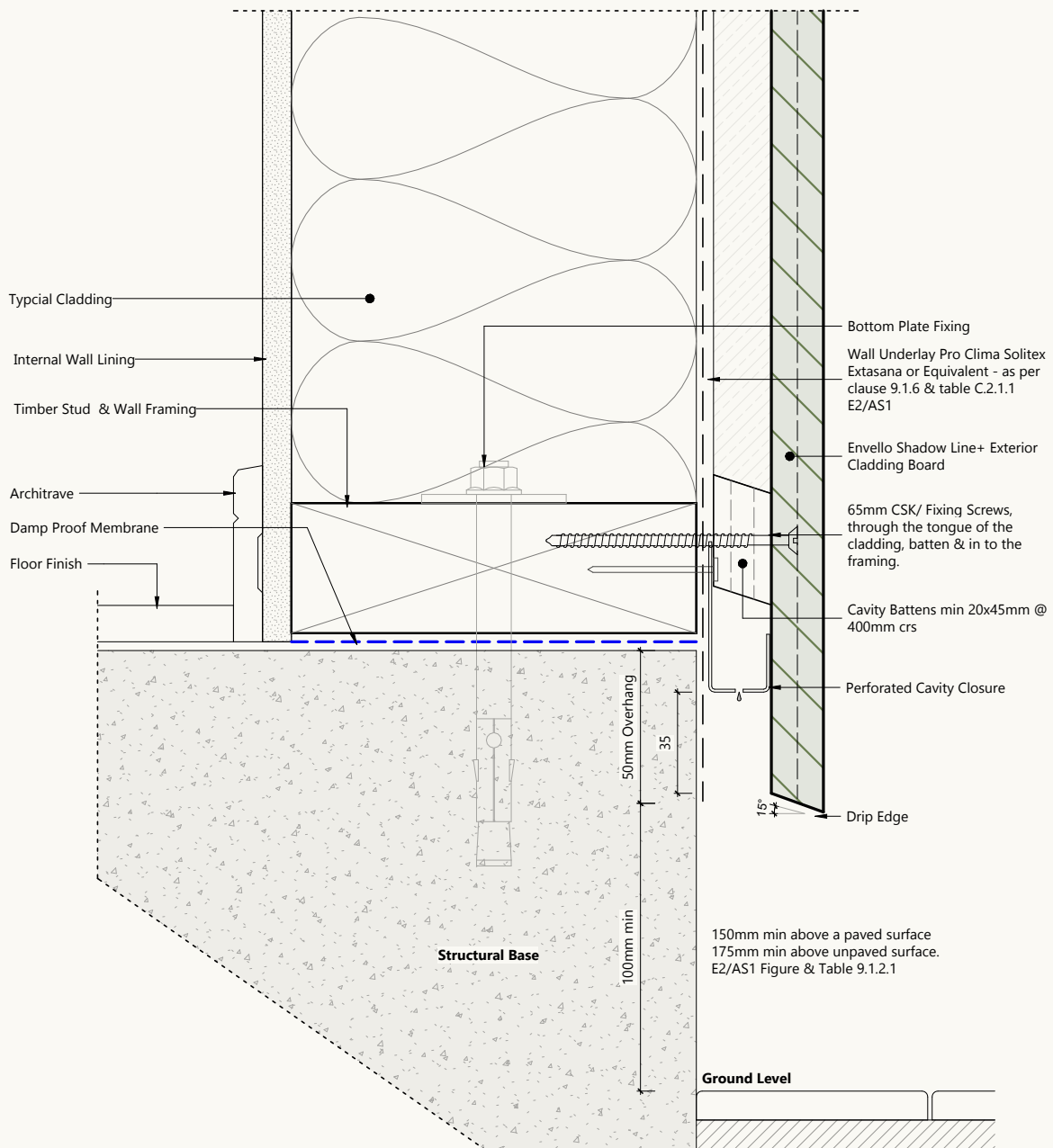

BASE TO WALL – ENCLOSED DECK

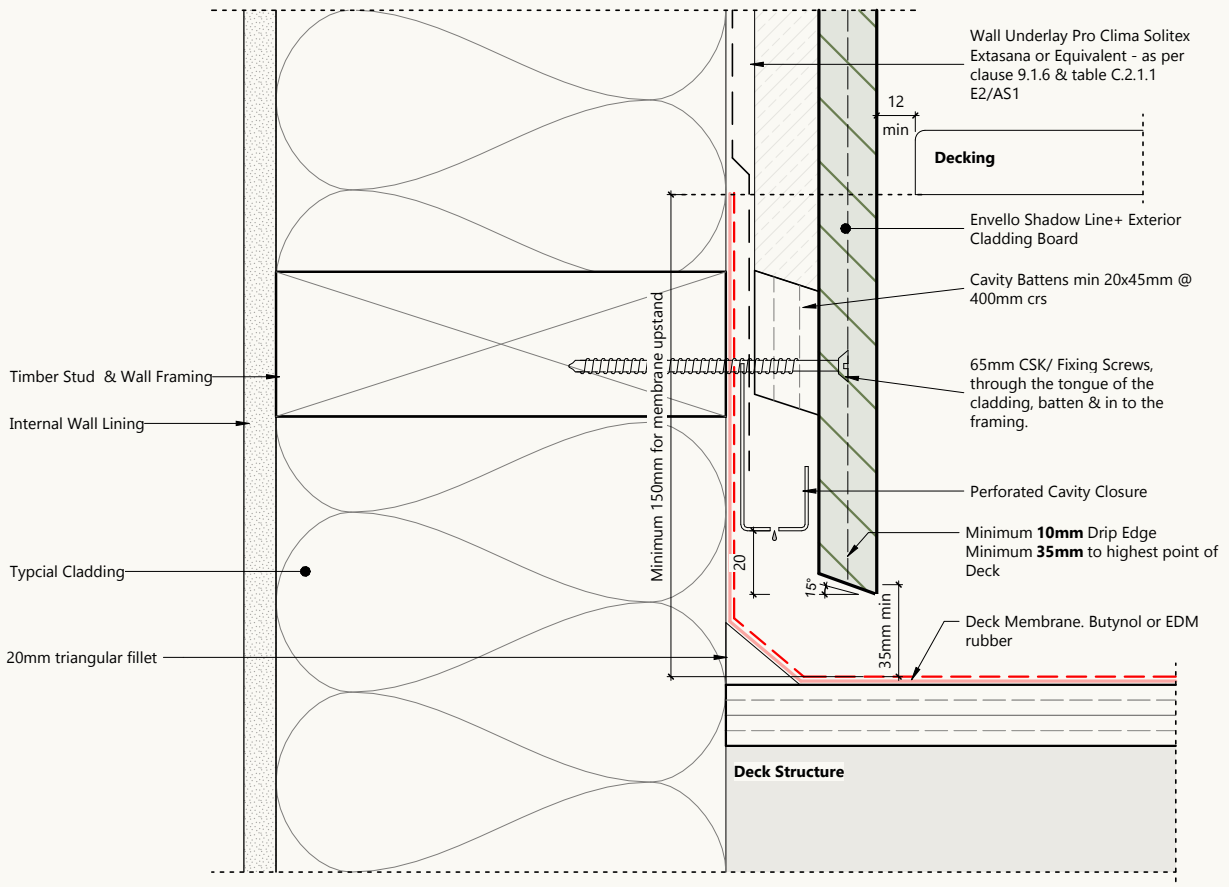

6.4

SOFFITS

WALL HEAD

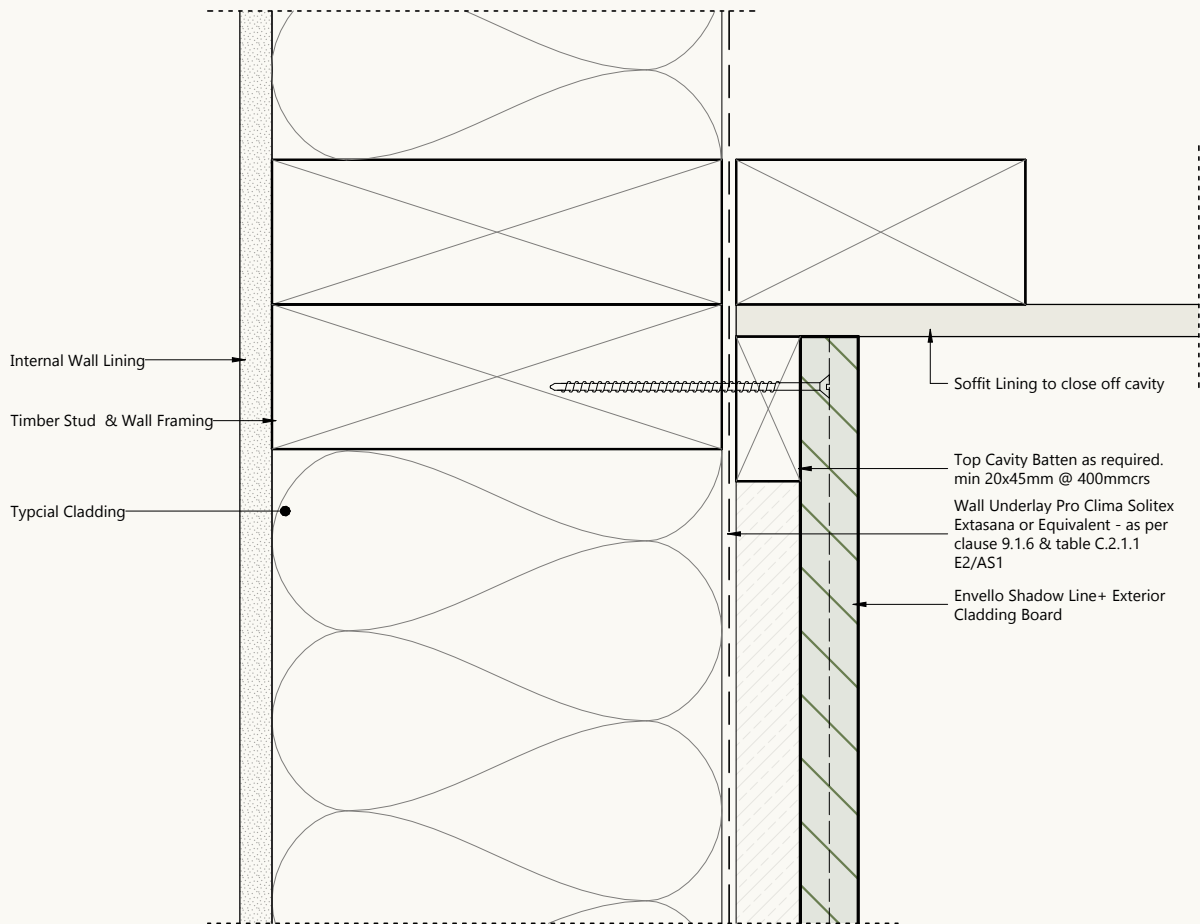

INSTALLATION



7.1	Corners	31	7.7	Barge Detail	44
7.2	Inter Story Junction	36	7.8	Parapets	45
7.3	Joining Boards	37	7.9	Transition to Brick/Monolithic	46
7.4	Windows and Doors	38			
7.5	Wall Penetrations	40			
7.6	Installation Abutting Rendered Surface	43			

7.1

CORNER DETAILING

Envello Shadow Line+ External Corner Profiles

SHADOW LINE+ EXTERNAL Y FLASHING

The External Y Flashing is designed to create a clean, seamless, mitred finish on external corners.

When installing the Y Flashings, ensure:

- Flashing is fixed with 20mm screws at 300mm centres on both sides of the Flashing.
- For multi-storey installations, overlap the upper flashing by 20mm over the lower, securing both sides of the flashing with 20mm screws for a neat, continuous detail.
- Ensure either side of the flashing is sealed using a continuous bead of Sikaflex FC11 sealant.

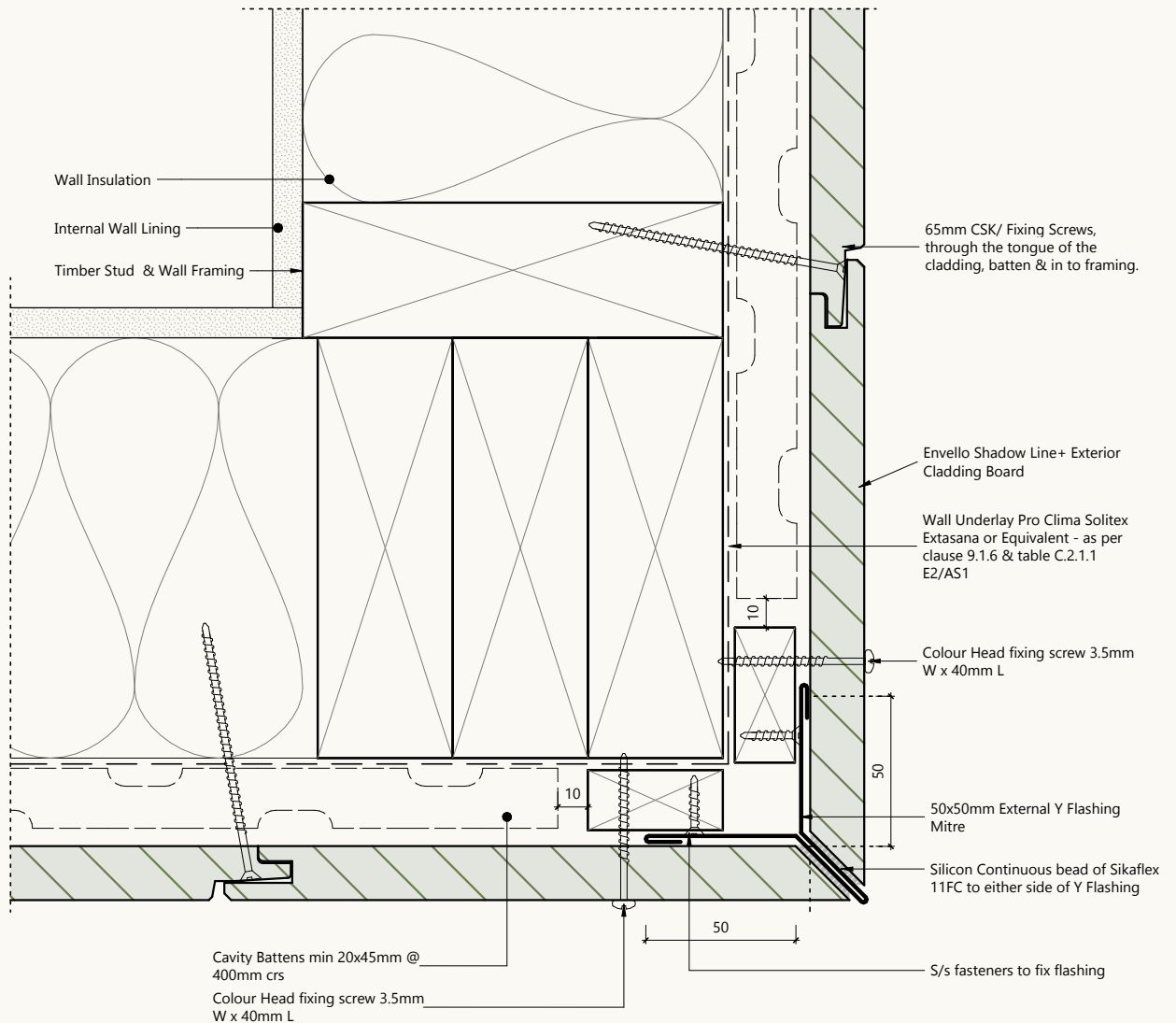

EXTERNAL MITRE FLASHING TRIM

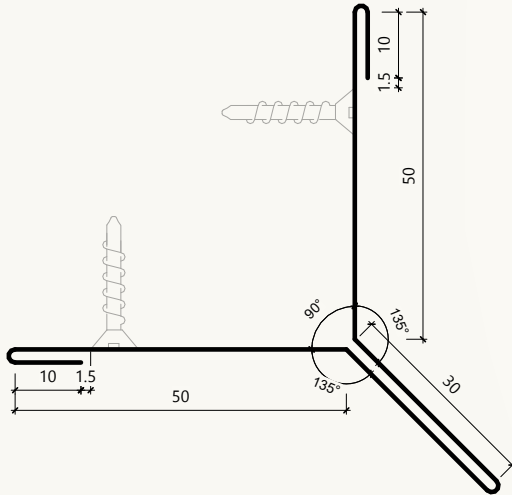

SECTION	50 x 50mm "Y" flashing profile
MATERIAL	Coloursteel external mitre (0.55 gauge).
FABRICATION	All folds to be clean and true; soft edges acceptable where required for forming
FINISH	Coloursteel to match adjacent cladding / trims, colour as scheduled
INSTALLATION	Fixed in accordance with specification recommendations and standard trade practice to ensure weather-tightness and durability
FIXING	Use 20 mm Envello fixings.

Y-HEM FLASHING FIXING NOTES

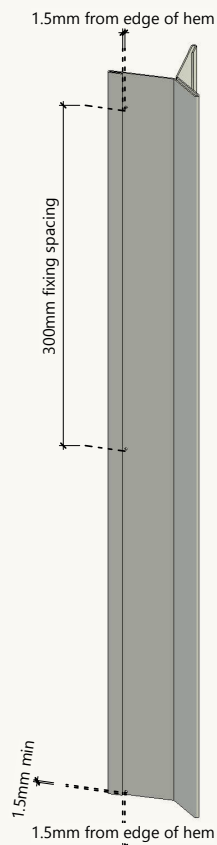

FIXING SPACING	Fasten flashings at a maximum of 300 mm intervals along the length
FIXINGS	Use 20 mm Envello fixings
Y-HEM FLASHING FIXING NOTES	End fixing 1.5 mm from the cut end and 1.5 mm from the edge (approximately 0.5 mm from the inner hem edge).

ENVELLO SHADOWLINE + EXTERNAL CORNER PROFILE

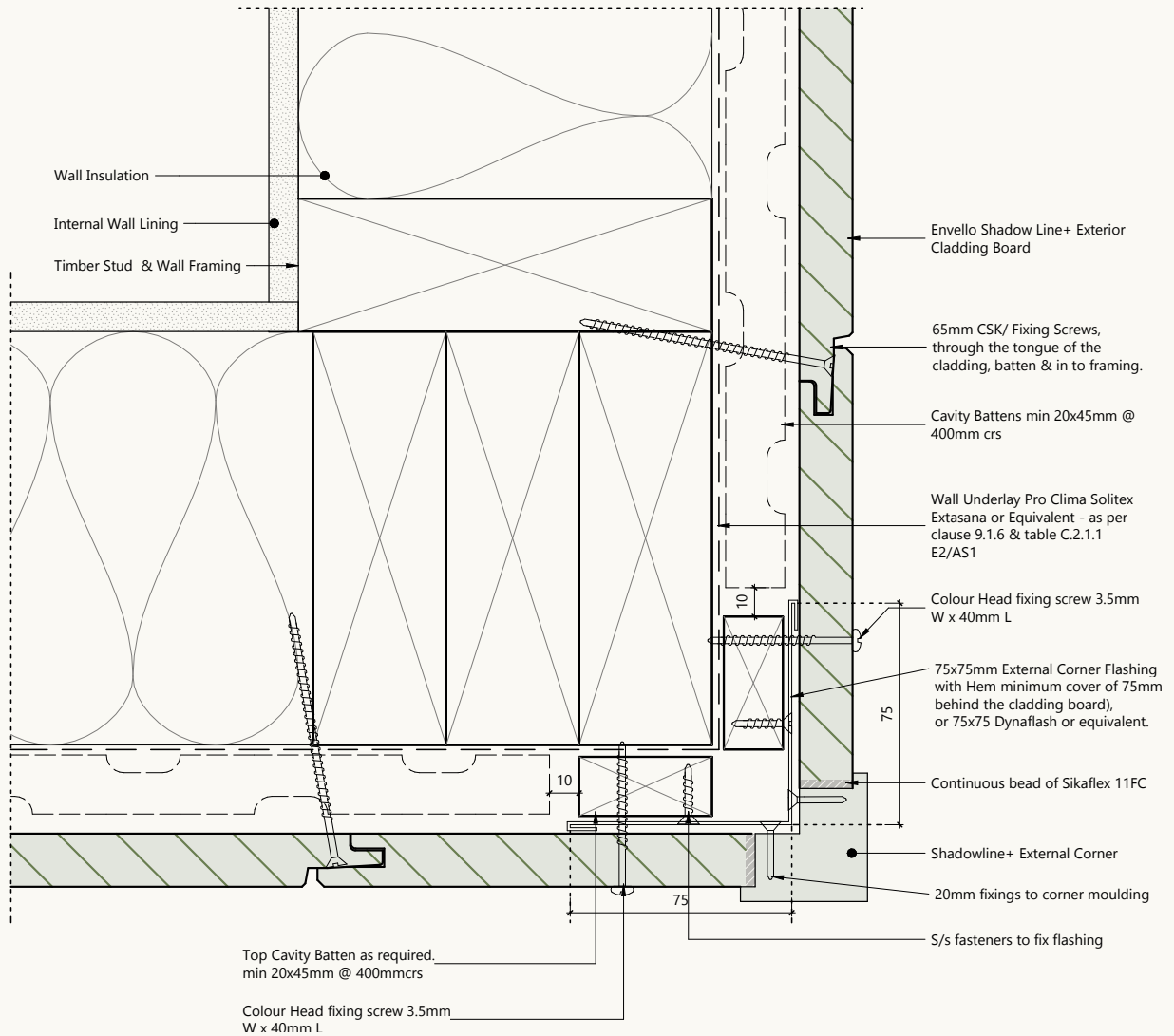

PERFORATED CLOSURES

Perforated closures are secured to the back of the corner profiles with accessory fixings, then fixed to the corner battens, ensuring stability and proper ventilation at the junction.

The perforated closure is fitted to the back of the corner profiles using the 20mm accessory fixings at 200mm centres. These are then fixed to the battens on the corner, as shown in Fig. 8-10.

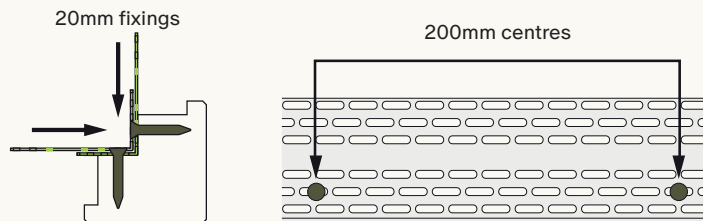

Fig. 8 - Use of perforated closure on corner profiles

JOINING CORNER PROFILES

We do not recommend joining multiple corner profile lengths together. Single length install only. Butt joining of multiple lengths together is not recommended due to the risk of movement in the joints.

Internal Corner Profile

INTERNAL BUTT JOINT

Internal corners can be finished by simply butting boards together.

Alternatively, the boards can be butted together on internal corner.

The boards can also be mitred to create the external corner, this would also be applicable if the corner is anything other than 90 degrees.

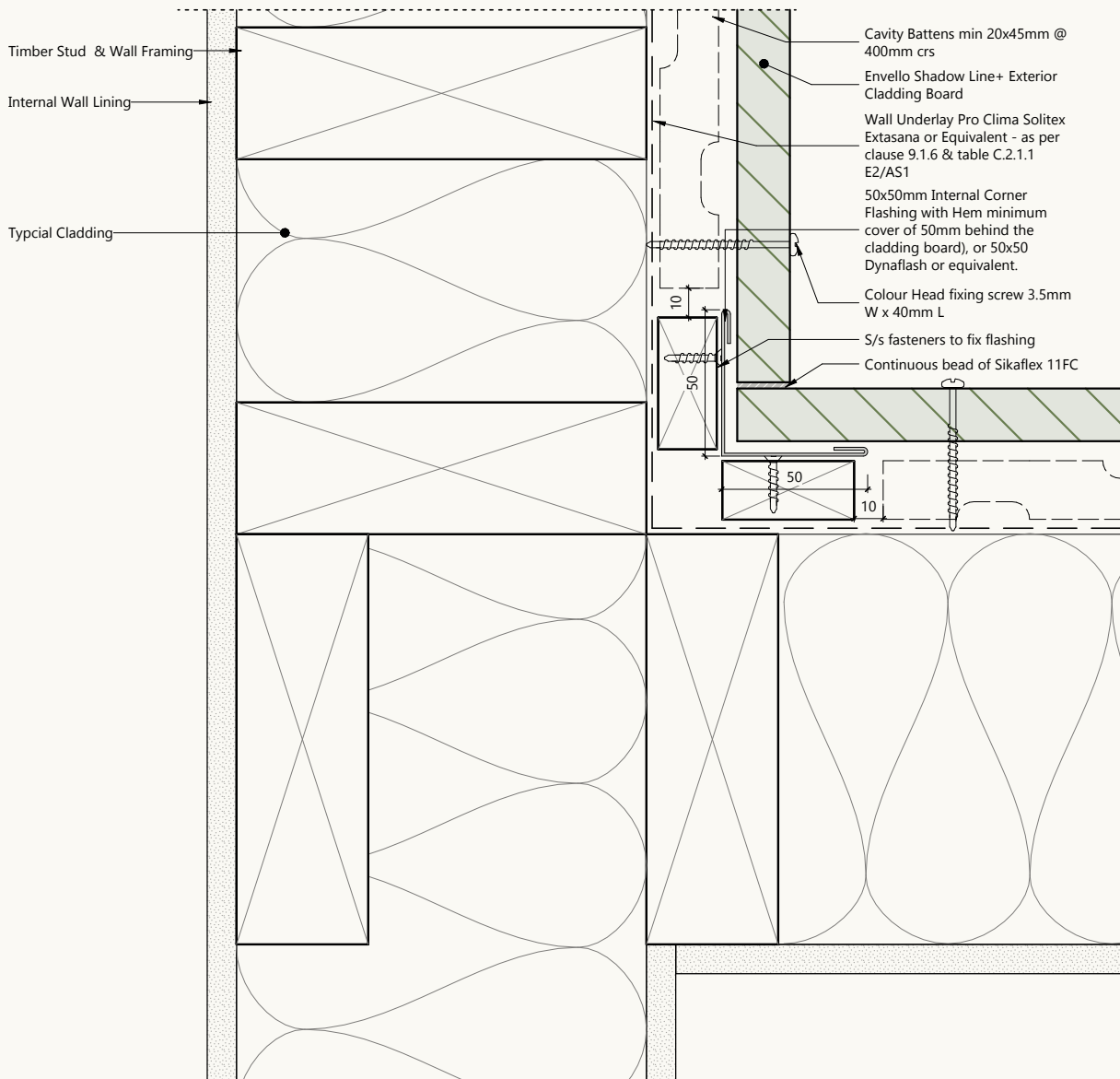

SHADOW LINE+ INTERNAL CORNER PROFILE

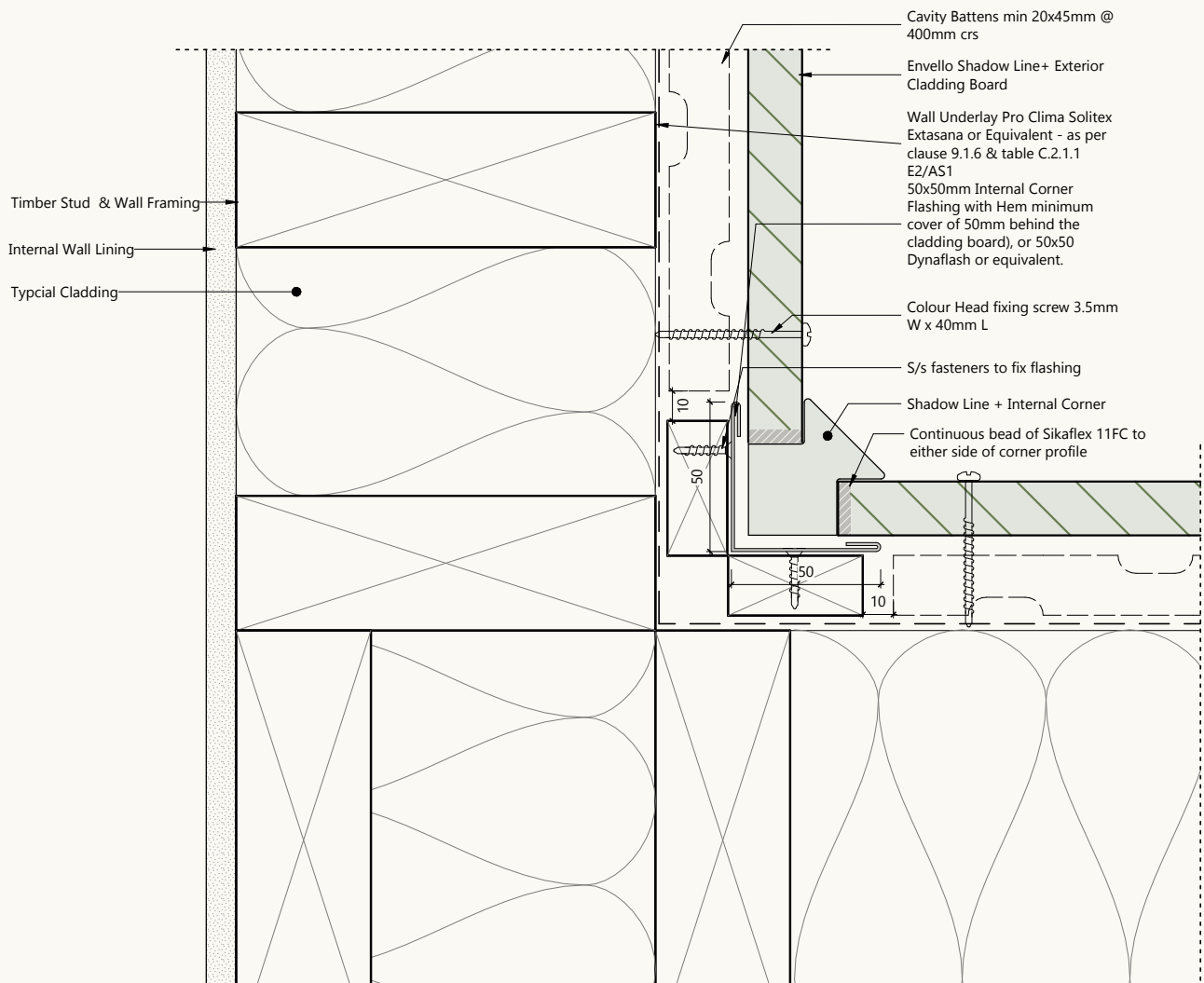

PERFORATED CLOSURES

Perforated closures are secured to the back of the corner profiles with accessory fixings, then fixed to the corner battens, ensuring stability and proper ventilation at the junction.

The perforated closure is fitted to the back of the corner profiles using the 20mm accessory fixings at 200mm centres. These are then fixed to the battens on the corner, as shown in Fig. 8.

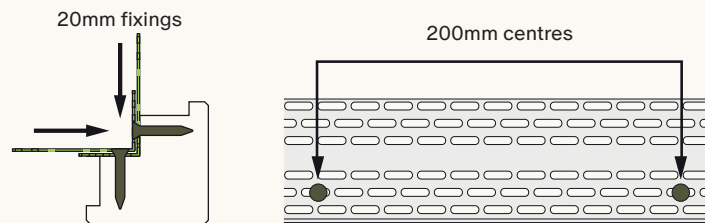

Fig. 8 - Use of perforated closure on corner profiles

JOINING CORNER PROFILES

We do not recommend joining multiple corner profile lengths together. Single length install only. Butt joining of multiple lengths together is not recommended due to the risk of movement in the joints.

7.2

INTER-STOREY CAVITY JUNCTION

Horizontal cladding joints require a flashing detail to allow for building movement, protecting the boards and ensuring long-term stability of the Envello cladding system.

When there is a horizontal joint between cladding areas, a flashing detail should be used to ensure boards aren't affected by any building movement. As Envello cladding is made from a resin mineral composition, it is more stable in comparison to timber or resin mineral board based on timber, and therefore acceptable movement is up to 0.2%.

HORIZONTAL JOINT

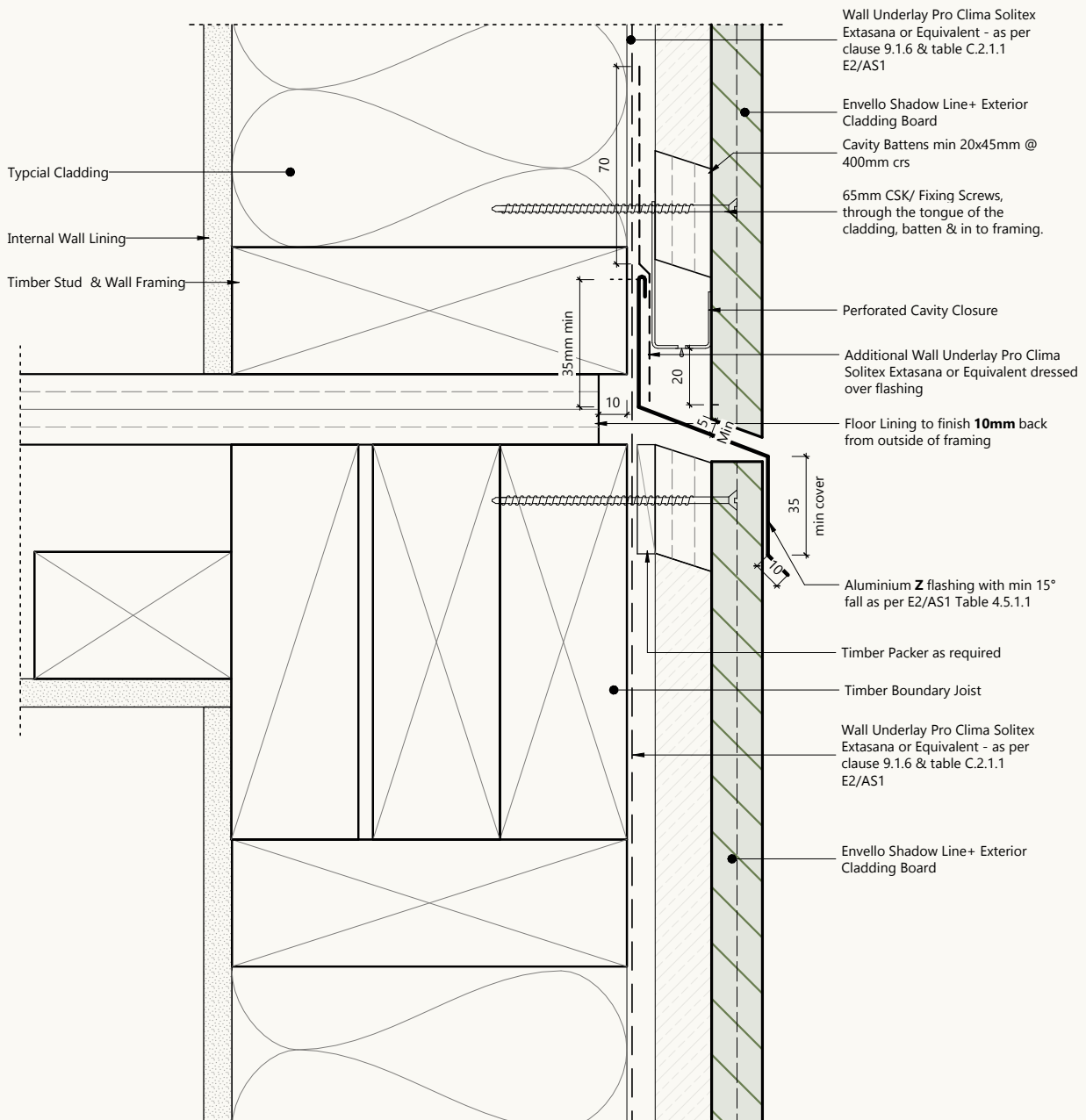

7.3

JOINING BOARDS

End-to-end board joins must be properly supported, staggered across the wall, and sealed for stability and a seamless appearance. Careful preparation ensures alignment and long-term performance.

When joining boards end-to-end, a batten must be used behind the boards to ensure both ends are supported equally. It is best to not have the joins all in one line, rather spread out across the cladding area.

As the boards are manufactured through a moulding process, we recommend all ends are trimmed before they are installed. Dry fit the boards first to make sure they align, using boards that are of appropriate dimensions to ensure a consistent finish.

We recommend that the boards are joined with a 20° scarf joint with one overlapping the other. The cut ends should be painted with touch-up coating for the best finish and Sikaflex 11FC sealant applied to the joint.

BOARD JOIN

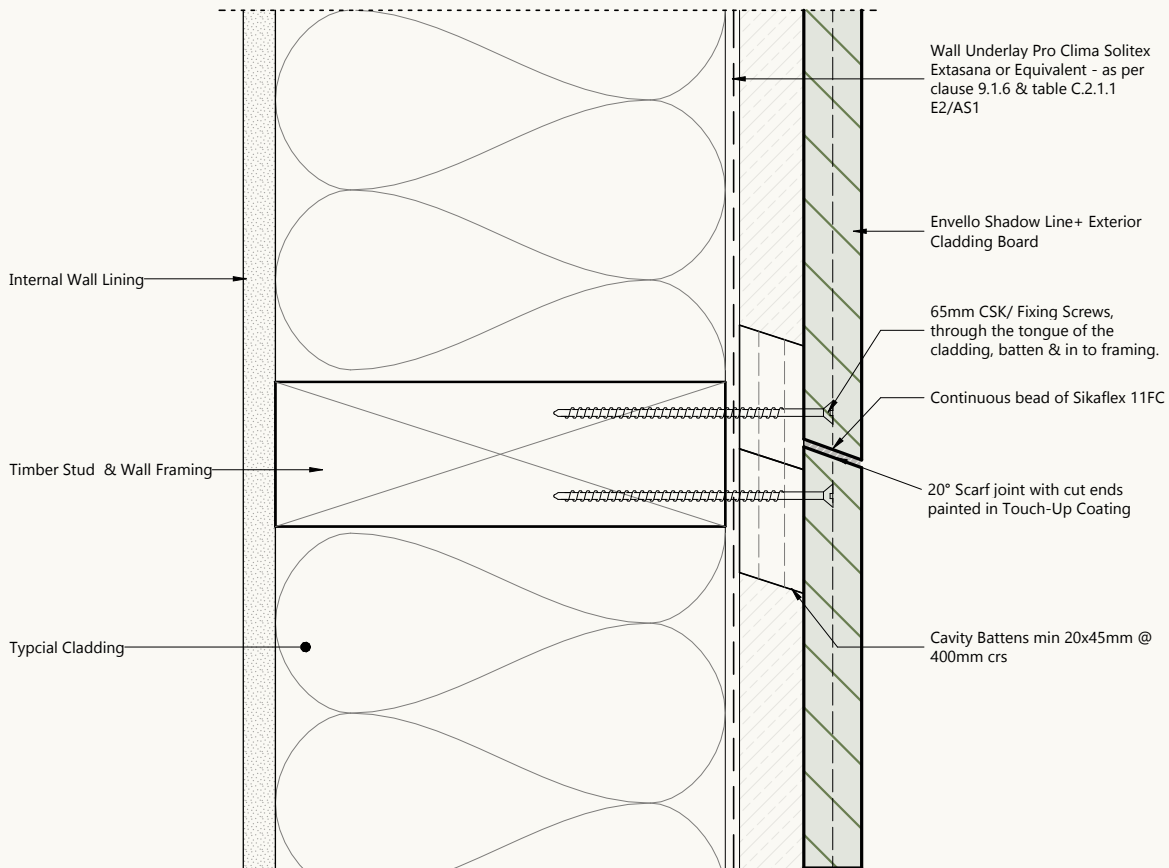

7.4

WINDOWS AND DOORS

Flashings must be correctly specified and installed to suit the cladding depth and joinery. Sourced from specialist suppliers, they ensure effective water management and compliance with NZBC E2/AS1.

Flashing trims around windows and doors will need to be sourced from other suppliers (e.g. the window manufacturer or flashing manufacturer). They should be designed to work with the window or door joinery as well as the depth of cladding and battens used. All flashings must be of sufficient grading and should be installed in accordance with NZBC E2/AS1.

Other details that require flashings will also need to be sourced from other suppliers, such as the flashings around a meter box or inter-storey joining details. The flashings shown throughout this guide are indicative and need to be confirmed by the manufacturer.

WINDOW HEAD

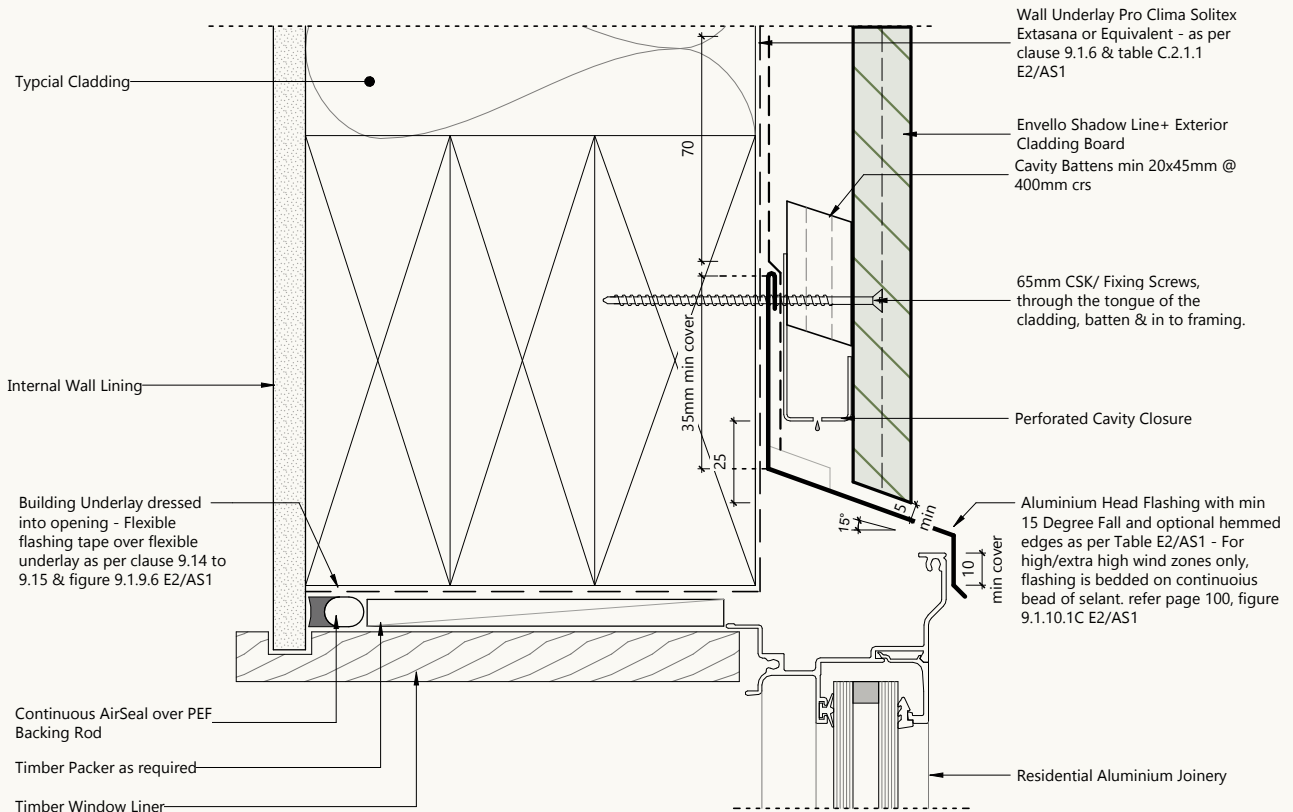

WINDOW JAMB

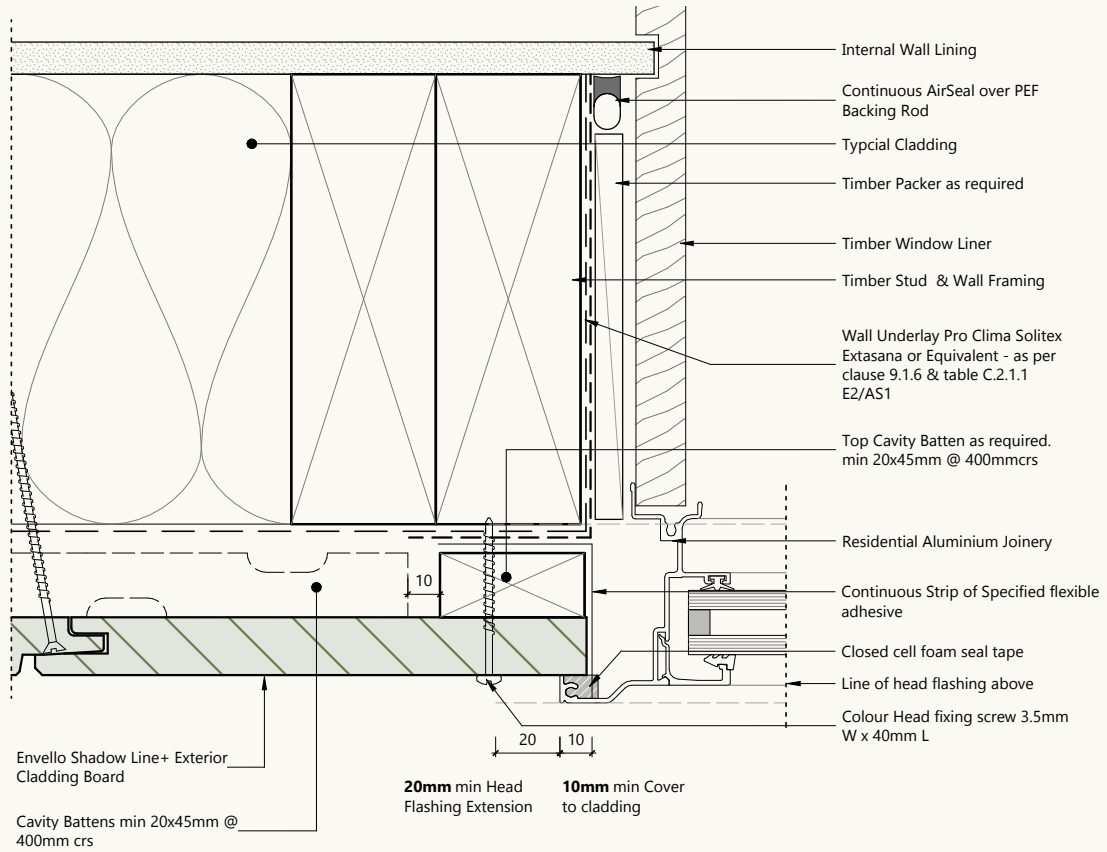

WINDOW SILL

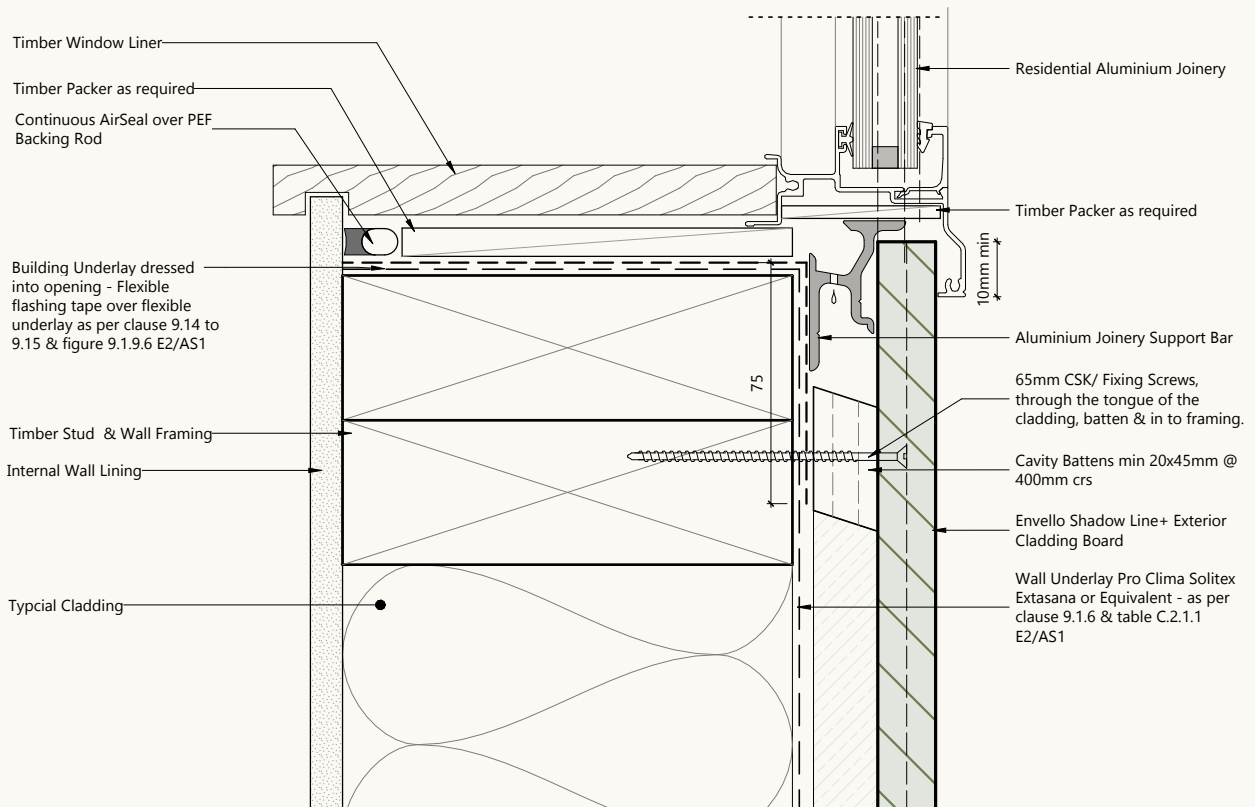

7.5

WALL PENETRATIONS

Careful detailing around penetrations and parapets is essential to maintain water tightness, ensure structural fixing, and protect the cladding's integrity in all weather conditions.

When installing around a metre box or other penetrations, the flashing detail must ensure a water and airtight seal whilst also allowing fixing points for the cladding boards. The cladding should be detailed so that the sealing around the meter box is not affected. Please note that the images shown are indicative and should be confirmed by the flashing manufacturer.

When installing cladding around pipes, please ensure the pipes are sufficiently sealed with backing rod and sealant, and that the cladding fixing doesn't affect the performance.

Where there is a parapet wall, the flashing on the parapet wall should be sealed and designed so that it allows for sufficient water runoff. The flashing needs to cover the cladding sufficiently for the wind zone according to NZBC E2/AS1.

Please note that anything that is fixed to the face of the cladding boards should not rely on the boards to be secure. The fixings should be fixed either into the structurally fixed battens or into the building structure, depending on the likely loads applied. If items are being fixed through the boards into the building structure, sufficient packing should be inserted behind the boards to help prevent any board deformation.

PIPE PENETRATIONS

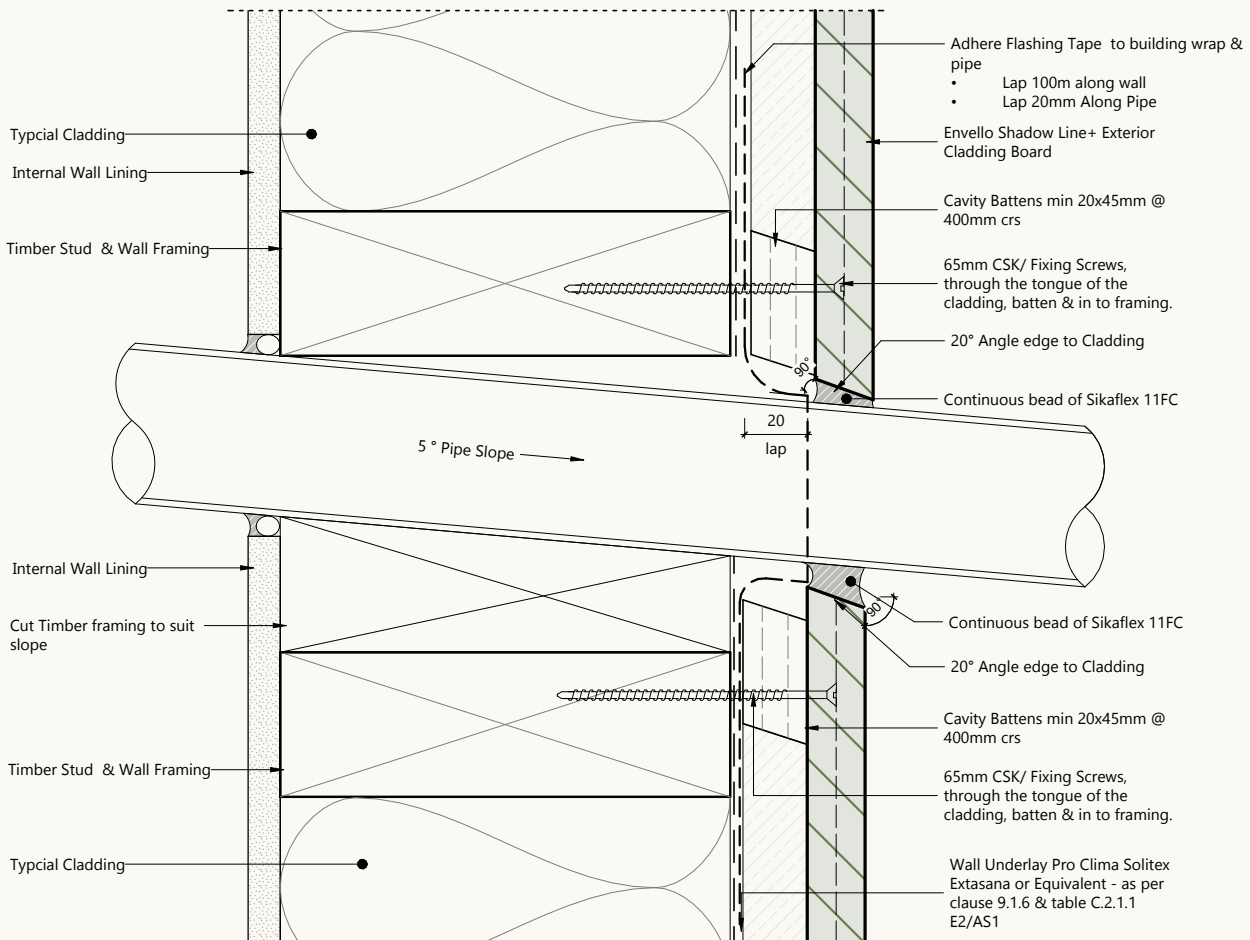

METER BOX HEAD

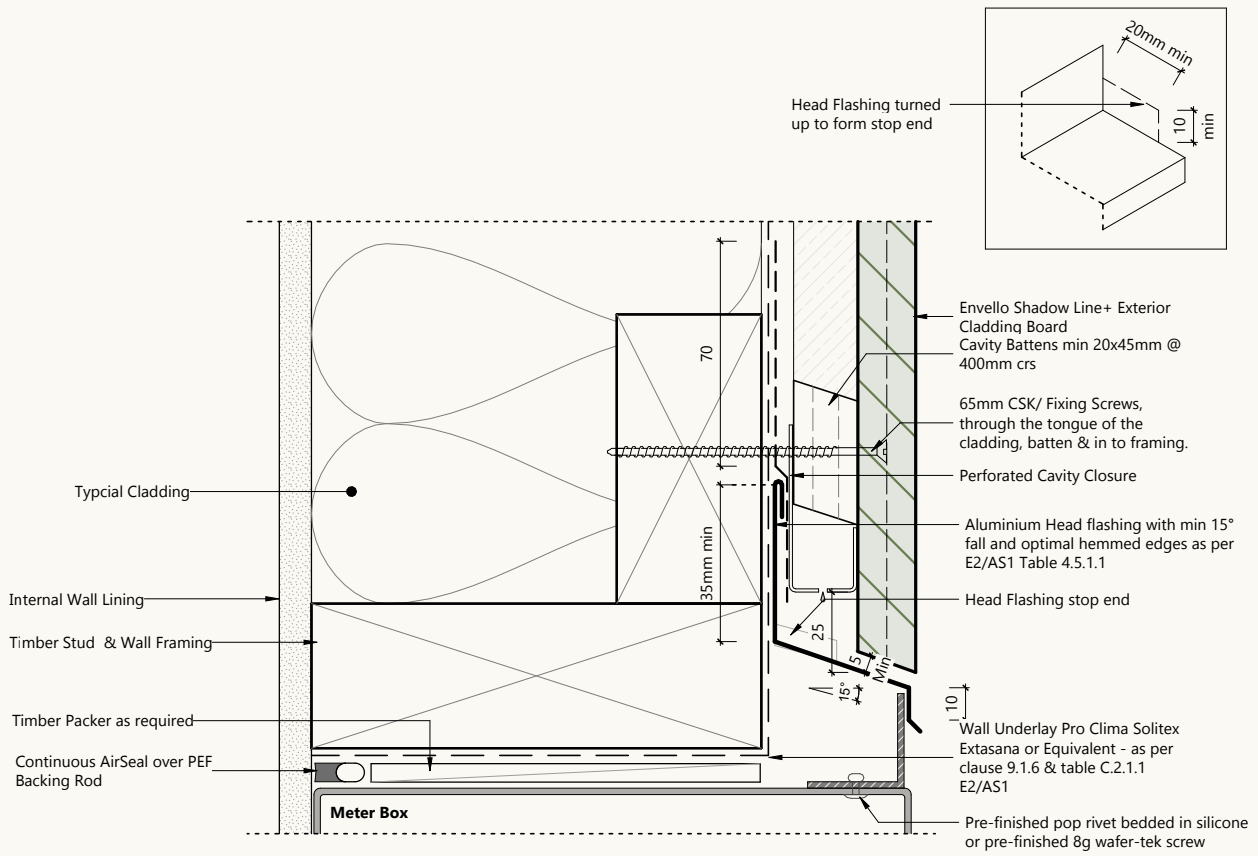

METER BOX SILL

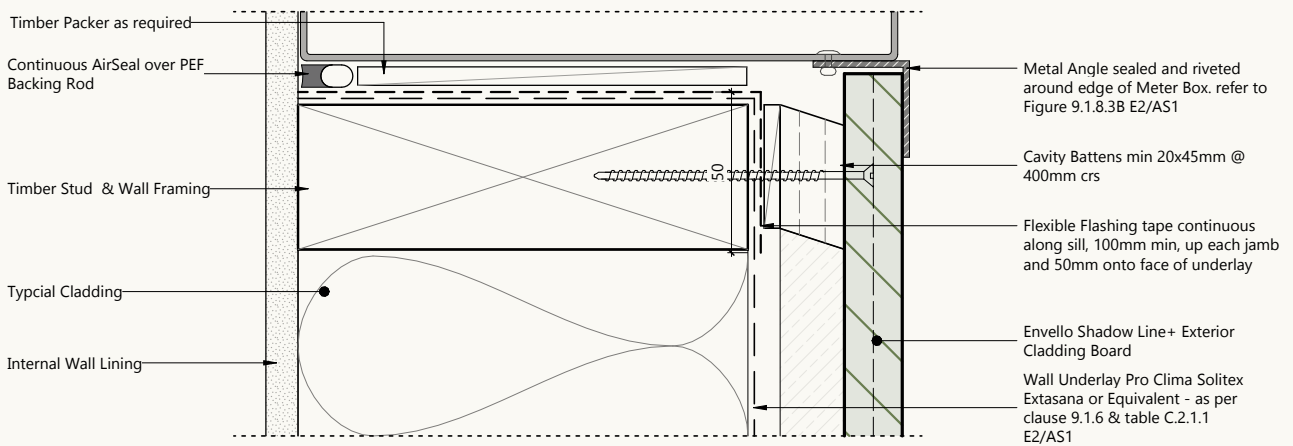

METER BOX JAMB

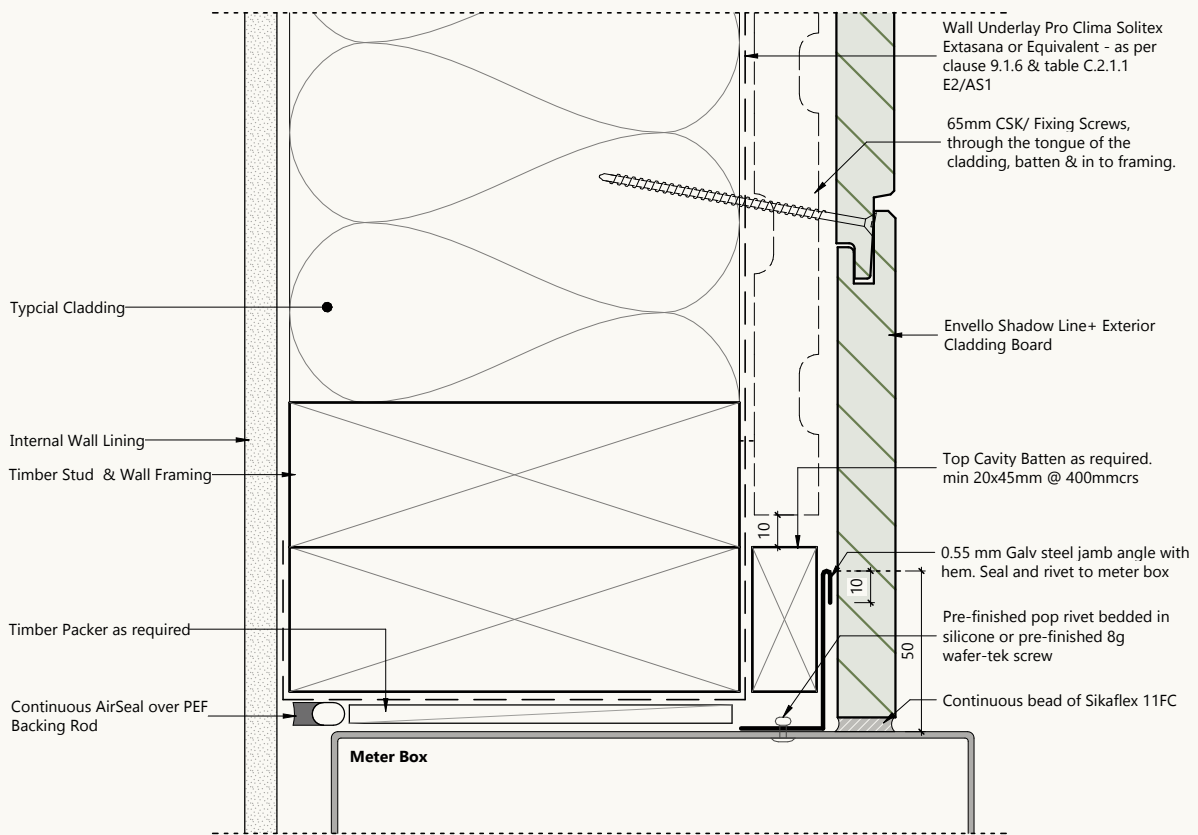

7.6

INSTALLATION ABUTTING RENDERED SURFACE

When installing Envello cladding next to render, allow for movement and water runoff using recommended gaps, sealants, corner profiles, and flashing for a weather-tight, professional finish.

The junction between Envello and render can be achieved in a number of different ways, however we'd recommend finishing the render up to a render stop bead rather than directly up to the cladding, before fitting the Envello cladding.

Please ensure a 5mm gap is left between the render stop and the edge of the cladding / corner profiles to allow for a backing rod and silicone sealant to be used. The junction between the Shadow Line+ boards and render on a corner can be done utilising corner profiles or reveal boards.

When installing cladding above the render, it is best to install a flashing detail that goes up behind the cladding battens and protrudes further than the render, to allow rainwater to run off the flashing detail.

EXTERNAL CORNER ABUTTING RENDER

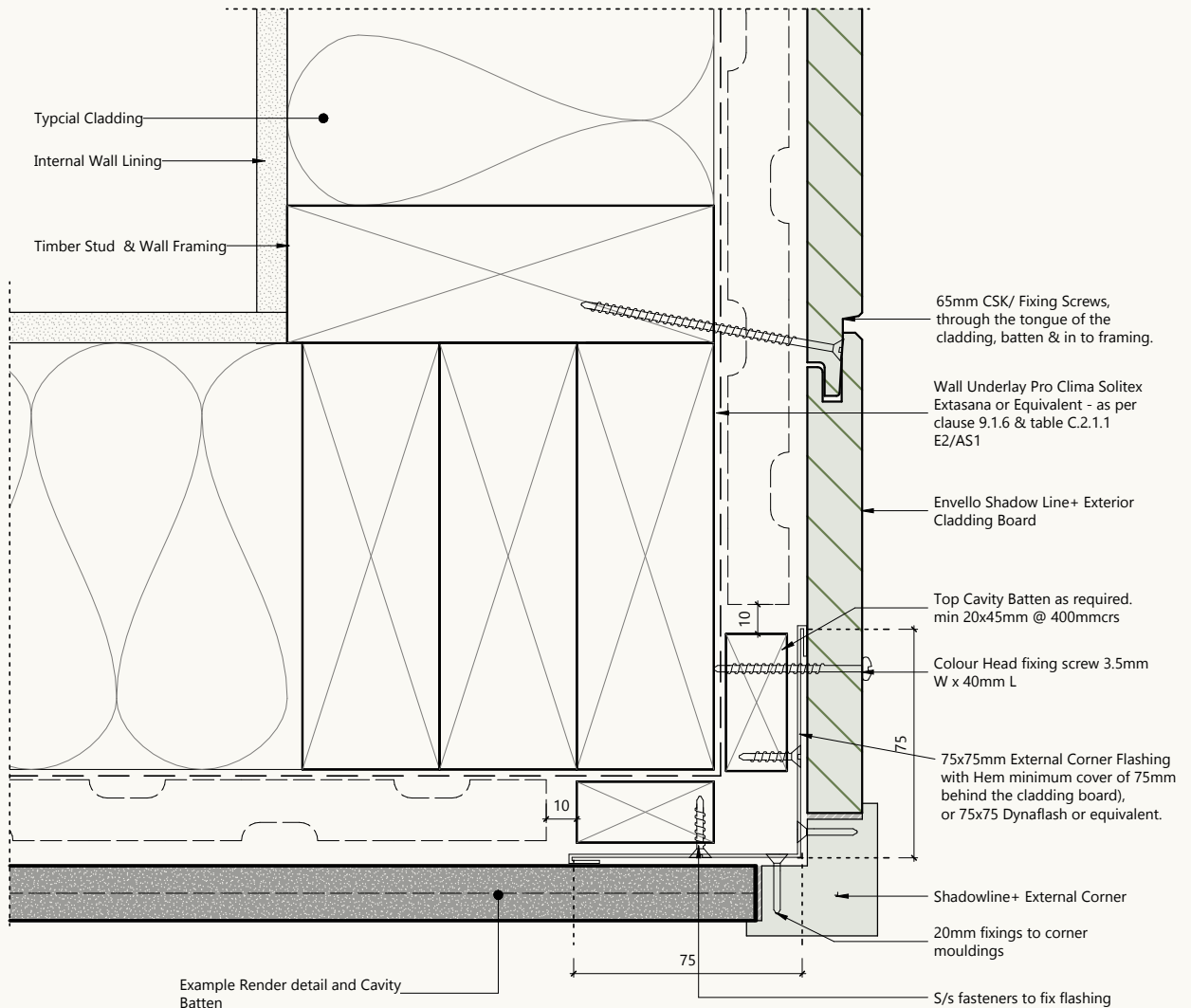

7.7

BARGE DETAIL

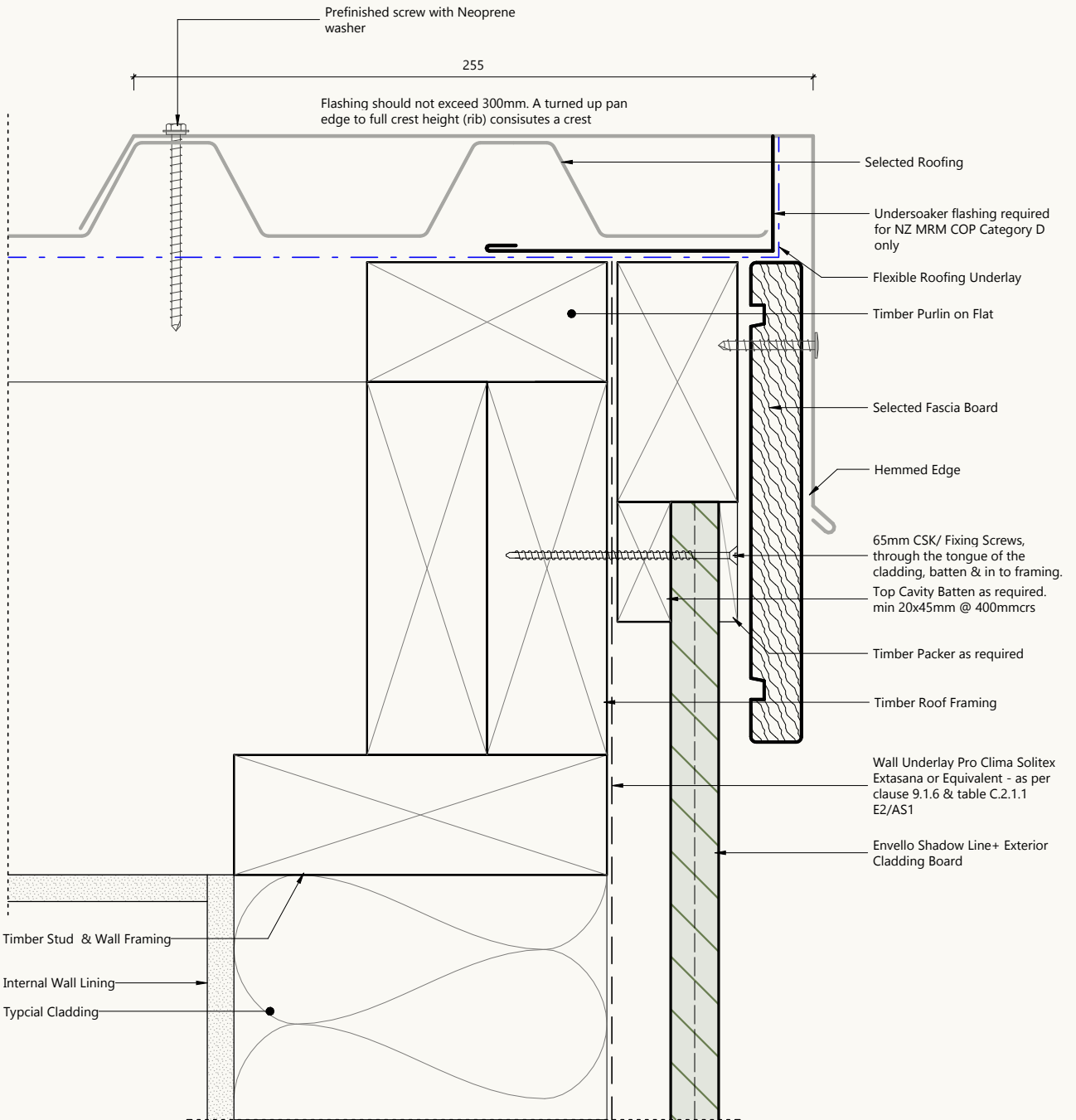

7.8

PARAPETS

Parapet junctions must incorporate compliant flashings, ensuring adequate coverage and water deflection in accordance with wind zone requirements and E2/AS1.

Where there is a parapet wall, a flashing is to be detailed to allow for sufficient water run-off and to be sealed.

The flashing needs to sufficiently cover the cladding for the wind zone requirements of the property.

- As per E2/AS1 6.1 and Figure 6.1.1.4.a and 4.5.1.1.
- Parapet to wall junctions are to be flashed to direct water clear of the outside of face of the cladding.

PARAPET FLASHING

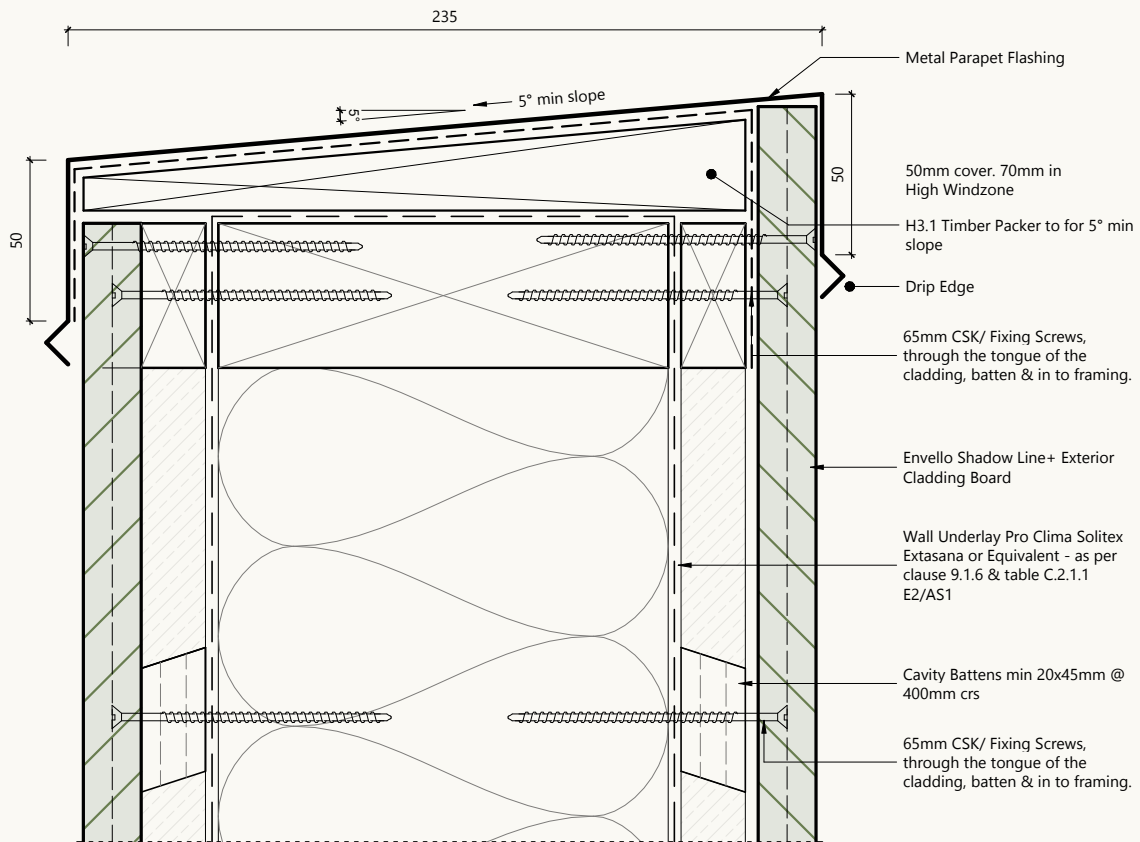

7.9

TRANSITION TO BRICK/MONOLITHIC

When transitioning from Envello cladding to brick or monolithic cladding, a small gap and some finishing are required for a clean, sealed look.

A 5mm gap should be left between the Envello cladding and the adjoining surface to accommodate a backing rod and SikaFlex 11 FC, ensuring a proper seal. The cut end of the board should also be painted with a touch-up coating to maintain a consistent colour finish – this is purely for aesthetic purposes.



Forté